

# HAMMER UNION



## THE HAMMER UNION

**Recommended service applications:** Cement pumping, hydrostatic testing, closed loop systems, chicksan tie in, and all SAE 100R12 and 100R13 2" applications

**Features:** Replaceable lip-type seals, provides primary seal, protects secondary metal-to-metal seal, one piece crimpable Hammer Union fitting

**Description:** 2" Hammer Union. Decimal 2 place .010, 3 place .005. Tolerance (Unless noted). Angular 1/2°, Fractional 1/64°. Concentricity .015 TIR

## PART LIST

ITEM NUMBER	PART NUMBER
1	Ring Cushion
2	1502-F32W
3	1502-M32W
4	Hammer Union Nut

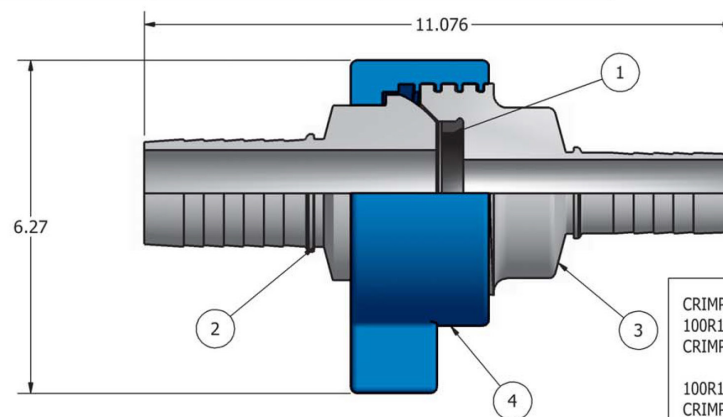

CRIMP SPECS:	
100R12	= NON-SKIVE
CRIMP DIA.	= 2.780
100R13	= SKIVE 2.500 TO THE WIRE
CRIMP DIA.	= 2.960

PROPRIETARY OF NRP JONES

## MADE IN THE USA

### Corporate Office & Manufacturing:

302 Philadelphia Street  
LaPorte, Indiana 46350  
Office: 219-362-9908  
Fax: 219-324-0815  
Customer Service Toll-Free Number 1-800-348-8868  
Order Entry Toll-Free Fax Number 1-800-207-2221  
Email sales@nrpjones.com

### Manufacturing Facility:

255 West 11th North  
Nephi, Utah 84648  
Office: 435-623-1740  
Fax: 435-623-2638  
Customer Service Toll-Free Number 1-800-453-1480  
Order Entry Toll-Free Fax Number 1-800-207-2221  
Email sales3@nrpjones.com

